

Received 23 October 2023; revised 26 December 2023; accepted 28 December 2023; published 30 December 2023

Implementing the Search Algorithm of the Correlation Interferometer Direction Finder through the GNU Radio Software Platform

Oleksiy Polikarovskiyh^{1,*} and Ihor Hula²

¹Department of Technical Cybernetics and Information Technologies, Odesa National Maritime University, Odesa, Ukraine

²Department of Physics and Electrical Engineering, Khmelnytskyi National University, Khmelnytskyi, Ukraine

*Corresponding author (E-mail: polalexey@gmail.com)

ABSTRACT In the realm of modern radio equipment development, the integration of Software Defined Radio (SDR) systems, encompassing both software and hardware components, has become widespread. SDR systems, particularly, find applications in the creation of direction finders for radio signal sources. The effectiveness of direction finding and the identification of radio radiation sources largely hinge on the technical specifications of the equipment. For contemporary systems aimed at detecting the location of radio radiation sources, direction finders based on a correlation interferometer prove to be highly suitable. These direction finders excel in performing direction finding for a wide array of radio signals, capable of recognizing broadband modulated signals. They can simultaneously process and identify several signals within a single frequency channel, originating either from a singular source of radio signals (coherent) or from multiple sources (incoherent). SDR technology enables programmable reconfiguration of a radio receiver through software. Such receivers boast a broadband radio frequency component with a significant dynamic range, a high-speed Analog-to-Digital Converter (ADC) path, a robust signal processor, and a specialized digital filtering path. SDR receivers are adaptable to signals of various standards and frequencies, depending on the specific tasks at hand. The GNU RADIO software platform stands out as the most flexible open-source software platform for SDR systems. This article delves into the utilization of the GNU RADIO software platform to implement the search algorithm for the direction finder of the correlation interferometer. The Ettus USRP N210 SDR platform was selected for implementing the direction finder using the correlation interferometer algorithm. This study introduces a two-channel software-controlled model of the direction finder, operating according to the correlation interferometer algorithm. The measurement results for the placement angle of radio signal sources yielded an individual absolute error ranging from 2 to 4 degrees, with an average absolute error of about 3 degrees. These results are quite commendable for such mobile two-channel systems. While systems with four or more channels boast higher accuracy, they tend to have lower economic feasibility.

KEYWORDS GNU RADIO, SDR, correlation interferometer algorithm.

I. INTRODUCTION

Radio direction finders belong to navigation equipment, the main task of radio direction finders is to determine the position of a moving object in space. With the proliferation of satellite positioning radio systems, direction finding for radio navigation tasks is becoming less and less used [1]. Nevertheless, radio direction finding is quite relevant for radio control tasks and detecting the location of radio sources [2]. The task of efficient direction finding of radio sources depends to a large extent on the technical characteristics of the equipment.

The structural diagram of radio direction finder shown in Fig. 1 consists of the following blocks: an antenna unit, a radio receiving unit, a digital signal processing unit, and an indication unit. Also, depending on the requirements, the following units can be added to the block diagram: a remote control unit via communication lines or radio channel; a navigation unit for orientation of the radio direction finder; a unit for testing the performance of the direction finder; devices for adjusting and calibrating radio receiving paths.

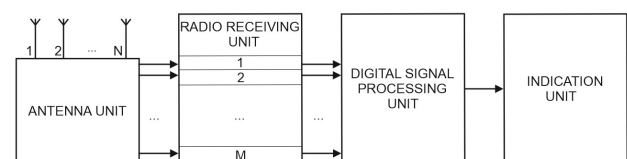

FIG. 1. Block diagram of the radio direction finder.

The direction finder antenna system consists of N antennas placed in space according to a certain law: ellipse or circle, other options are possible. Antennas of various designs can be used as direction finder antennas: directional antennas of various types, frame antennas, conical vibrators, disco-cone antennas, and others.

The radio receiving unit is used to select, amplify, and convert the frequency of the input signals. From the output of the radio receiving unit (Fig. 1), analog signals at an intermediate frequency are sent to the digital signal processing unit, where these signals undergo an analog-to-digital conversion operation. According to the method used for direction finding, the azimuth position of the radio sources is determined. The digital signal processing device can also perform spectral analysis of signals,

measure their parameters, demodulate and decode information [3]. The display unit shows the direction finding results. A personal computer or a laptop is often used as a display unit. The computer is also used to control the operation of direction finding equipment, store direction finding results, etc.

Currently, the following types of radio direction finders are used for radio source location systems: based on a rotating directional antenna; quasi-Doppler systems; phase interferometers; correlation interferometers; two-channel automatic direction finders [4].

Different types of direction finders have their advantages. Modern systems for detecting the location of radio sources, direction finders based on a correlation interferometer are best suited, as they can track almost all types of radio signals [5]. Such direction finders can recognize broadband modulated signals, simultaneously process and recognize several signals in the same frequency channel, both from one radio source (coherent) and from several sources (incoherent) [6].

II. PROPOSED SYSTEM ARCHITECTURE

The basic idea of a correlation interferometer is to compare the measured phase differences between the antenna array elements and the phase differences of a reference (theoretical) spatial signal [7]. This reference signal is supposed to be calculated analytically for all possible angles of arrival of the radio wave. The direction of the reference spatial signal, where the correlation with the received signal is maximized, is considered the angle of arrival of the radio wave [8]. For systems detecting the location of radio sources, the most common is the scheme with two receiving channels, which is shown in Fig. 2:

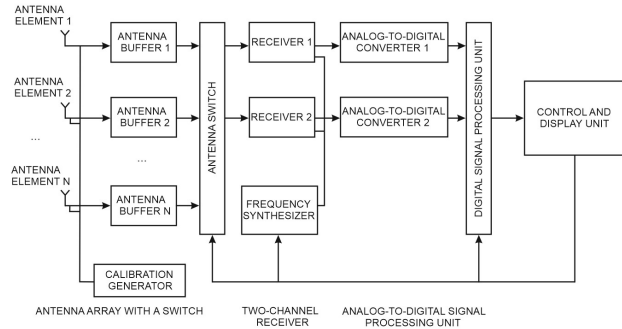

FIG. 2. Block diagram of a correlation interferometer.

In this arrangement, where the number of antenna elements exceeds the number of receiving channels, all elements are connected in series to the receiver inputs using high-frequency switches. The key components of a correlation interferometer include an antenna array, an antenna switch, a dual-channel coherent receiver, and an analog-to-digital processing unit.

The antenna switch connects pairs of antenna elements selected by the direction finding algorithm to the inputs of the two-channel receiver in series. To ensure coherent signal reception, the mixers of both radio reception channels are supplied with the same high-frequency voltage generated by the frequency synthesizer. The main functions of the two-channel receiver are frequency conversion of the received radio signal and primary filtering on the side channels.

The analog-to-digital processing unit performs basic computing operations according to the digital processing algorithm. The control and display device included in the interferometer performs control functions and provides a user interface.

The algorithm of operation of the correlation interferometer for detecting the location of radio sources is as follows [9]. In the case of an annular antenna array, the complex amplitude is represented as:

$$\dot{E}_n = E_0 \exp \left[j \left(2\pi \frac{R_n}{\lambda} \cos(\theta_0 - \alpha_n) \sin \beta_0 + \varphi(t) + \varphi_0 \right) \right], \quad (1)$$

where $R_n = |\bar{R}_n|$ – radius of the ring on which the antenna elements are placed; α_n – is the location angle n-th of the antenna array element, which is counted counterclockwise from the x-axis. The superposition of radio signals from different radio sources is received by the antenna array elements and sent to the inputs of the antenna switch, which passes the signals from the selected pair of antennas to the two inputs of the panoramic receiver. The radio signals received at the receiver inputs are transferred to an intermediate frequency in the receiver.

In a panoramic receiver, the frequency band for simultaneous viewing is much larger than the signal spectrum width of a single radio source. Consequently, a large number of radio channels can operate simultaneously in the frequency band received by the receiver, as shown in Fig. 3. The signals in these channels can have different spectral widths and belong to different classes of radiation.

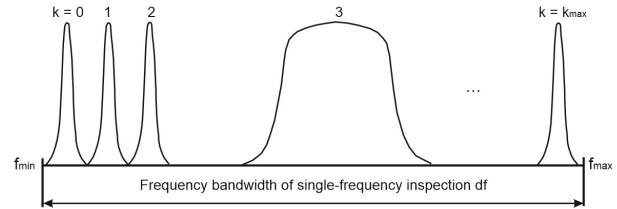

FIG. 3. Spectra of radio signals simultaneously received by a panoramic receiver.

From a pair of receiver outputs, the intermediate frequency signals are sent to the ADC inputs, where they are synchronously converted into digital signals with a length of N_1 samples. Using the discrete Fourier transform, we obtain N_1 complex spectral samples for each signal. Subsequently, to simplify the calculations, only $N_1/2$ complex counts of each spectrum are used [9]. The signal spectrum in the k-th radio channel corresponds to the signal of the k-th radio source. Considering the ratio:

$$E = U / h_L, \quad (2)$$

where E – electromagnetic field intensity; U – voltage at the antenna output; h_L – is the actual length of the measuring antenna, the complex signal amplitudes in the k-th radio channel for the signal $Z_c(n_1, t)$ and reference $Z_0(n_2, t)$ paths are as follows:

$$Z_c(n_1, t) = h_H E_0 K \sin \beta_0 \times \exp \left[j \left(2\pi \frac{R_{n1}}{\lambda} \cos(\theta_0 - \alpha_{n1}) \sin \beta_0 + \varphi(t) + \varphi_0 + \varphi \right) \right]; \quad (3)$$

$$Z_0(n_2, t) = h_H E_0 K' \sin \beta_0 \times \exp \left[j \left(2\pi \frac{R_{n_2}}{\lambda} \cos(\theta_0 - \alpha_{n_2}) \sin \beta_0 + \varphi(t) + \varphi_0 + \varphi' \right) \right], \quad (4)$$

where h_H – is the actual height of the antenna element for the k -th radio channel connected to the receiver input; E_0 – is the amplitude of the electromagnetic field intensity of the radio signal in the k -th radio channel; K, K', φ, φ' – are the gain and phase delays of the signal of the signal and reference paths of the receiver, respectively, for the k -th radio channel; n_1, n_2 – numbers of the antenna array elements, $n_1 \neq n_2$; $\alpha_{n_1}, \alpha_{n_2}$ – angles of the antenna array elements. As a result of the detection operation, the values of the center frequencies of the radio channels are known f_k in the simultaneous analysis band df and width of the radio channel dF . The hardware implementation determines the analysis band df . The values of the radio channel numbers $\{k\}, 1 \leq k \leq k_{\max}, k_{\max} = df/dF$, in which radio signals are detected are recorded in memory. Each of these numbers corresponds to the values of the radio channel boundaries, converted to spectrum component numbers, taking into account the analysis band df , volume N_1 and width of the radio channel dF . By assigning serial numbers to the components in the radio channel spectrum, sequences of spectrum samples corresponding to the frequency bands of radio channels are obtained. For radio channels in which a signal is detected, multiply the complex samples in the signal spectrum in the signal path $S_c(k, i, n_1)$ with the complexly related samples of the signal spectrum of the reference path $S_0(k, i, n_2)$, and add the resulting products:

$$\dot{A}_{n_1, n_2} = \sum_i \dot{S}_c(k, i, n_1) \dot{S}_0(k, i, n_2), \quad (5)$$

where κ – radio channel number, $1 \leq \kappa \leq k_{\max}$; i – spectrum reference number in the channel, $i = 0, 1, \dots, q-1$. As a result of summing the products in spectral samples with the same name for the k -th radio channel, a spectral component is formed that corresponds to the unmodulated carrier frequency the radio signal. Taking into account expressions (3), (4), (5) we obtain the interference signal vector:

$$\dot{A}_{n_1, n_2} = (hE_0 \sin \beta_0)^2 K K' \exp \left[j \left(\Delta \Phi_{n_1, n_2} + \varphi - \varphi' \right) \right], \quad (6)$$

where the phase shift

$$\Delta \Phi_{n_1, n_2} = \frac{2\pi}{\lambda} \left[R_{n_1} \cos(\theta_0 - \alpha_{n_1}) - R_{n_2} \cos(\theta_0 - \alpha_{n_2}) \right] \times \sin \beta_0. \quad (7)$$

The values of phase shifts $\Delta \Phi_{n_1, n_2}$ depend on the direction of arrival of the radio signal, on the angle γ_{n_1, n_2} of the direction finding pairs orientation, and on the base b_{n_1, n_2} between the n_1 -st and n_2 -nd antenna elements.

To ensure measurement accuracy, a prerequisite is to ensure the identity of the complex transmission coefficients in the radio receiving channels. At the present stage of electronics development, the construction in a broadband two-channel radio receiving device with the same transmission coefficients of radio receiving channels is a rather difficult technical task. In this regard, it is

advisable to use a two-channel radio receiving device with signal and reference channels and a common heterodyne in a direction finder based on [21-31] the correlation interferometer algorithm.

III. EXPERIMENTAL RESULTS

To implement the search algorithm of the correlation interferometer direction finder, we propose to use the SDR system with the GNU RADIO software environment [10]. A radio receiver using SDR technology can be programmatically reconfigured with the help of software. Such a radio receiver has an ultra-wideband radio frequency part with a large dynamic range, a high-speed ADC path, a powerful signal processor and a specialized digital filtering path [11, 12]. SDR receivers can receive signals of different standards and frequencies, the choice of which depends on the specific tasks [13, 14].

The most flexible modern software platform for SDR systems is the open source GNU RADIO software platform. Device circuits in the GNU RADIO software environment are built from blocks. A block is an elementary unit of signal processing, the so-called "black box", which has several inputs and outputs. By connecting the same type of outputs and inputs of different blocks, device block diagrams are built. We can connect blocks both programmatically (in Python, C++) and in the GNU Radio companion graphical editor. GNU Radio in C++ implements an algorithm for processing signals inside a block using Python strapping for blocks. The main blocks in GNU RADIO are signal source blocks, consumer blocks, and intermediate blocks. Signal sources can be, for example, software signal generators, sound card input interfaces, files with recorded information, and others. Consumers are software spectrum analyzers, sound card output interfaces, software oscilloscopes, intermediate units (filters, detectors, etc). The GNU RADIO software interface has a large library of graphical widgets in the form of blocks. There are blocks that can be used to divide the signal processing into several working PCs.

To implement the direction finder using the correlation interferometer algorithm, the Ettus SDR platform USRP N210 was chosen [15]. The block diagram of the test direction finder is shown in Fig. 4:

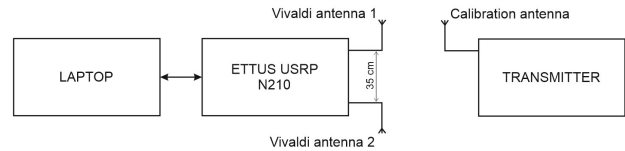

FIG. 4. Block diagram of the direction finder on the USRP N210 platform.

Since the USRP N210 is designed for use with such software platforms as GNU Radio, LabVIEW, and Simulink. To test the proposed implementation, a radio transmitter was used as a radio signal source, which was configured to generate a non-modulated sinusoidal signal at a frequency of 433MHz. This frequency falls within the frequency range of the USRP N210 device [16]. To detect the generated signal, both channels of the USRP N210 are tuned to the center frequency of 433MHz. The antennas

are located at a distance of 35 cm, which corresponds to half the wavelength [17]. The proposed system consists of the USRP N210 SDR platform with two channels connected to Vivaldi antennas, a laptop with the GNU RADIO software platform installed, and an RF transmitter [18].

Figure 5 shows the software implementation of the direction finder using the correlation interferometer algorithm in the GNU RADIO environment [19, 20]. The

software model of the direction finder consists of the following blocks: SDR receiver unit (SDR Source), two blocks of thinning FIR filters (Decimating FIR Filter), two blocks of stream to vector converters (Stream to Vector), a graphical interface unit in the frequency domain (QT GUI Frequency), a correlation interferometer unit (Cross Correlator), a vector to stream converter unit (Vector to Stream), a graphical interface unit in the time domain (QT GUI Time Sink).

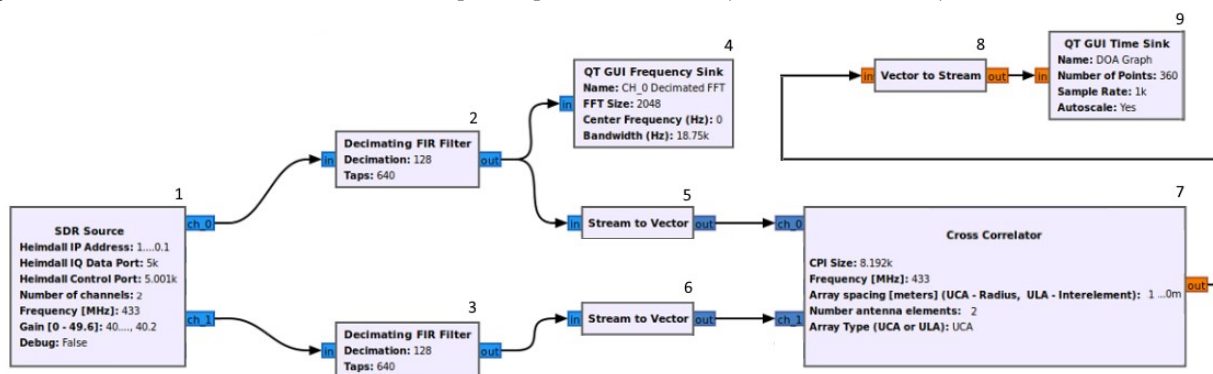

FIG. 5. Software model of the direction finder using the correlation interferometer algorithm.

The absolute and relative errors in measuring the angle of the radio signal source, the absolute and relative errors were determined using the formulas:

$$\Delta = |\varphi_{mea} - \varphi_{act}|, \quad (8)$$

where φ_{mea} – measured angle of the source, degrees; φ_{act} – actual angle of the source, degrees.

$$\varepsilon = \frac{|\varphi_{mea} - \varphi_{act}|}{\varphi_{act}} * 100\%. \quad (9)$$

TABLE 1. Names and parameters of functional blocks used in the software model of the correlation interferometer, Fig. 5.

No	Unit	Parameters
1	SDR Source	IP Address: 1...0.1 IQ Data Port: 5k Control Port: 5.001k Number of channels: 2 Frequency [MHz]: 433 Gain [0 - 49.6]: 40...40.2 Debug: False
2	Decimating FIR Filter	Decimation: 128 Taps: 640
3	Decimating FIR Filter	Decimation: 128 Taps: 640
4	QT GUI Frequency Sink	Name: CH_0 Decimated FFT FFT Size: 2048 Center frequency (Hz): 0 Bandwidth (Hz): 18.75k
5	Stream to Vector	Stream to vector converter
6	Stream to Vector	Stream to vector converter
7	Cross Corelator	CPI Size: 8.192k Frequency [MHz]: 433 Array spacing [meters]: 1...0 m Number antenna elements: 2 Array Type (UCA or ULA): UCA
8	Vector to Stream	Vector to stream converter
9	QT GUI Time Sink	Name: DOA Graph Number of Points: 360 Sample Rate: 1k Autoscale: Yes

The results of measuring the angle of the radio signal source are shown in Fig. 6; the calibration source was placed at different angles from -90 to 90 degrees.

From the figure we see that the absolute error in measuring the direction angle to the radio wave source lies in the range of [1.94..3.86] degrees, which for the case of two antennas is a high result for the given experimental conditions.

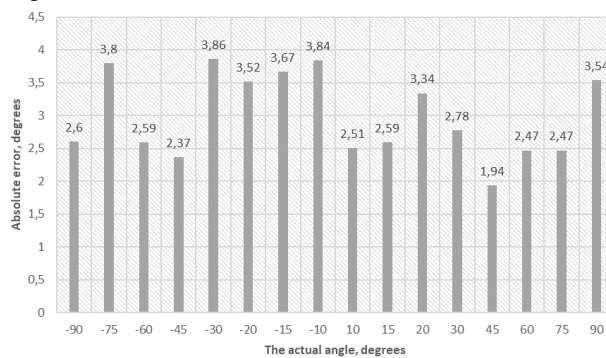

FIG. 6. Graph of the absolute error dependence on the angle of the radio source.

IV. CONCLUSION

This paper introduces a two-channel software-controlled model for a direction finder based on the correlation interferometer method. The measurements of the radio signal source angles resulted in an individual absolute error ranging from approximately 2 to 4 degrees, with an average absolute error of around 3 degrees. This level of accuracy is considered satisfactory for mobile two-channel systems. Although systems with four or more channels offer higher accuracy, they exhibit a significantly lower economic return on investment.

To enhance the accuracy of this system in the future, one potential avenue is the utilization of a different type of antenna. For instance, employing a modern TCI 643

antenna equipped with 9 TEM horns featuring expandable band elements (similar to a Vivaldi antenna) or an R&S ADD197 antenna with a single-channel receiver and a switch, accompanied by a set of phase rotators, holds promise for improving system precision.

AUTHOR CONTRIBUTIONS

O.P. – conceptualization, investigation, methodology, writing-review; I.H. – writing-original and editing draft preparation.

COMPETING INTERESTS

The authors declare no competing interests.

REFERENCES

- [1] Ghaemi K., Ma R., Behdad N.: A Small-Aperture, Ultrawideband HF/VHF Direction-Finding System for Unmanned Aerial Vehicles. *IEEE Transactions on Antennas and Propagation* 66(10), 2018, 5109–5120 [http://doi.org/10.1109/TAP.2018.2858210].
- [2] Liao B, Wen J, Huang L, Guo C, Chan S-C (2016) Direction finding with partly calibrated uniform linear arrays in nonuniform noise. *IEEE Sens J* 16(12):4882–4890 [DOI: 10.1109/TAP.2011.2173144].
- [3] Orduyilmaz A, Kara G, Gürel AE, Serin M, Yildirim A, Soysal G (2018) Real time four channel phase comparison direction finding method. In: 2018 26th signal processing and communications applications conference (SIU). IEEE Press, Izmir, pp 1–4 Design Concepts for Mobile Computing Direction Finding Systems [DOI: 10.1109/SIU.2018.8404590].
- [4] Oleksiy Polikarovskiykh, Juliy Boiko, Vitalii Tkachuk, Hanna Yehoshyna, Yuri Daus, "Neural Network Method of Directing Finder Signals Processing in Perimeter Protection Systems", 2023 13th International Conference on Advanced Computer Information Technologies (ACIT), pp.488-491, 2023.
- [5] Jensen M. A., Mahmood A., Mehmood R.: A compact low-cost direction-finding system for unmanned aerial vehicles. *Proceedings of 12th European Conference on Antennas and Propagation EuCAP 2018, London 2018*, 1–4 [http://doi.org/10.1049/cp.2018.0983].
- [6] Wong K. T., "Direction finding/polarization estimation-dipole and/or loop triad(s)", *IEEE Trans. Aerosp. Electron. Syst.*, vol. 37, no. 2, pp. 679-684, Apr. 2001. [DOI: 10.1109/7.937478].
- [7] Lee J-H, Kim J-K, Ryu H-K, Park Y-J (2018) Multiple array spacings for an interferometer direction finder with high direction-finding accuracy in a wide range of frequencies. *IEEE Antennas Wirel Propag Lett* 17(4):563–566 [DOI: 10.1109/LAWP.2018.2803107].
- [8] Mollai S, Farzaneh F (2019) Wideband two-dimensional interferometric direction-finding algorithm using base-triangles and a proposed minimum planar array. *AEU-Int J Electron C* 105:163–170 [https://doi.org/10.1016/j.aeue.2019.04.017].
- [9] Sobhani G, Pezeshk AM, Behnia F, Sadeghi M (2021) Joint detection of carrier frequency and direction of arrival of wide-band signals using sub-nyquist sampling and interferometric direction finding. *AEU—Int J Electron Commun* 139:153926 [https://doi.org/10.1016/j.aeue.2021.153926].
- [10] GNU Radio. The Free & Open Soft Radio Ecosystem. URL: <https://www.gnuradio.org>
- [11] Stewart R.W., Crockett L., Atkinson D., Barlee K., Crawford D., Chalmers I., et al. A low-cost desktop software defined radio design environment using MATLAB, simulink, and the RTL-SDR // *IEEE Communications Magazine*. 2015. Vol. 53. Iss. 9. PP. 64–71. [DOI:10.1109/MCOM.2015.7263347].
- [12] Wyglinski A.M., Orofino D.P., Ettus M.N., Rondeau T.W. Revolutionizing software defined radio: case studies in hardware, software, and education // *IEEE Communications Magazine*. 2016. Vol. 54. Iss. 1. PP. 68–75. [DOI:10.1109/MCOM.2016.7378428].
- [13] Belisle C., Kovarik V., Pucker L., Turner M. The software communications architecture: two decades of software radio technology innovation // *IEEE Communications Magazine*. 2015. Vol. 53. Iss. 9. PP. 31–37. DOI:10.1109/MCOM.2015.7263343.
- [14] Bilén S.G., Wyglinski A.M., Anderson C., Cooklev T., Dietrich C.B., Farhang-Boroujeny B., et al. Software-Defined Radio: A New Paradigm for Integrated Curriculum Delivery // *IEEE Communications Magazine*. 2014. Vol. 52. Iss. 5. PP. 184–193. [DOI:10.1109/MCOM.2014.6815911].
- [15] Ettus Research. URL: <https://www.ettus.com>
- [16] El-Hajjar M., Nguyen Q.A., Maunder R.G., Ng S.X. Demonstrating the Practical Challenges of Wireless Communications Using USRP // *IEEE Communications Magazine*. 2014. Vol. 52. Iss. 5. PP. 184–193. [DOI:10.1109/MCOM.2014.6815911].
- [17] Stockbroeckx B., Vander Vorst A.: Copolar and cross-polar radiation of Vivaldi antenna on dielectric substrate. *IEEE Transactions on Antennas and Propagation* 48(1), 2000, 19–25 [http://doi.org/10.1109/8.827381].
- [18] Kazici S., Loutridis A., Caratelli D.: A Novel Class of Super-Elliptical Vivaldi Antennas with Enhanced Radiation Properties. *IEEE International Symposium on Antennas and Propagation and USNC-URSI Radio Science Meeting, Atlanta 2019*, 259–260 [http://doi.org/10.1109/APUSNCURSINRSM.2019.8888948].
- [19] Bilén S.G., Wyglinski A.M., Anderson C., Cooklev T., Dietrich C.B., Farhang-Boroujeny B., et al. Software-Defined Radio: A New Paradigm for Integrated Curriculum Delivery // *IEEE Communications Magazine*. 2014. Vol. 52. Iss. 5. PP. 184–193. [DOI:10.1109/MCOM.2014.6815911].
- [20] Petrova M., Achtzehn A., Mähönen P. System-oriented communications engineering curriculum: teaching design concepts with SDR platforms // *IEEE Communications Magazine*. 2014. Vol. 52. Iss. 5. PP. 202–209. [DOI:10.1109/MCOM.2014.6815913].
- [21] Kim JS, Woong Woo D, Jeong H-C, Choi G-G, Kim SS (2019) A compact radome mounted monopulse antenna for direction-finding applications. In: 2019 IEEE international symposium on antennas and propagation and USNC-URSI radio science meeting. IEEE Press, Atlanta, pp. 2197–2198 [DOI: 10.1109/APUSNCURSINRSM.2019.8888393].
- [22] Ko C-B, Lee J-H (2018) Performance of ESPRIT and root-MUSIC for angle-of-arrival (AOA) estimation. In: 2018 IEEE world symposium on communication engineering (WSCE). IEEE Press, Singapore, pp 49–53 [DOI: 10.1109/WSCE.2018.8690541].
- [23] Li W, Zhu Z, Gao W, Liao W (2022) Stability and super-resolution of MUSIC and ESPRIT for multi-snapshot spectral estimation. *IEEE Trans Signal Process* 70:4555–4570 [DOI: 10.1109/TSP.2022.3204454].
- [24] Chan YT, Lee BH, Inkol R, Yuan Q (2001) Direction finding with a four-element Adcock-Butler matrix antenna

- array. IEEE Trans Aerosp Electron Syst 37(4):1155–1162 [DOI: 10.1109/7.976956].
- [25] Othman MAB, Belz J, Farhang-Boroujeny B (2017) Performance analysis of matched filter bank for detection of linear frequency modulated chirp signals. IEEE Trans Aerosp Electron Syst 53(1):41–54 [DOI: 10.1109/TAES.2017.2649162].
- [26] Abd El-Alim OA, Agrama EE, Ezz-El-Arab ME (1991) Second-order discriminant function for amplitude comparison monopulse antenna systems (EW antenna array). IEEE Trans Instrum Meas 40(3):596–600 [DOI: 10.1109/19.87025].
- [27] Bailey M. C., Campbell T. G., Reddy C. J., Kellogg R. L. and Nguyen P., "Compact wideband direction-finding antenna", IEEE Antennas Propag. Mag., vol. 54, no. 6, pp. 44–68, Dec. 2012. [DOI: 10.1109/MAP.2012.6387781].
- [28] P. E. Pace, D. Wickersham, D. C. Jenn and N. S. York, "High-resolution phase sampled interferometry using symmetrical number systems", IEEE Trans. Antennas Propag., vol. 49, no. 10, pp. 1411–1423, Oct. 2001. [DOI: 10.1109/8.954930].
- [29] J. H. Lee, J. Lee and J. Woo, "Method for obtaining three- and four-element array spacing for interferometer direction-finding system", IEEE Antennas Wireless Propag. Lett., vol. 15, pp. 897–900, 2016. [DOI: 10.1109/LAWP.2015.2479224].
- [30] J. H. Lee and J. Woo, "Interferometer direction-finding system with improved DF accuracy using two different array configurations", IEEE Antennas Wireless Propag. Lett., vol. 14, pp. 719–722, 2015. [DOI: 10.1109/LAWP.2014.2377291].
- [31] C.-S. Park and D.-Y. Kim, "The fast correlative interferometer direction finder using I/Q demodulator", Proc. Asia-Pac. Conf. Commun., pp. 1–5, 2006. [DOI: 10.1109/APCC.2006.255915].



Oleksiy Polikarovskyykh

In 2015, he received a Doctor of Science degree (D.Sc. in Engineering) at the State University of Intellectual Technologies and Communication (Odesa, Ukraine) in the field of signal synthesis in telecommunication systems. In 2019 Full Professor of the Department of Telecommunications Technologies, Khmelnytsky National University (Khmelnytsky, Ukraine). Currently, Full Professor of the Department of Technical Cybernetics and Information Technologies, Odesa National Maritime University (Odesa, Ukraine). Research includes issues related to the development of devices for signal synthesis, the theory of cybersecurity and Software Defined Radio.

ORCID ID: 0000-0002-1893-7390



Ihor hula

In 2014, he received a PhD in Engineering from Vinnytsia National Technical University (Vinnytsia, Ukraine) with a degree in Radio Measuring Devices. In 2020, he became an associate professor at the Department of Physics and Electrical Engineering, Khmelnytsky National University (Khmelnytsky, Ukraine). Currently Associate Professor at the Department of Physics and Electrical Engineering, Khmelnytsky National University (Khmelnytsky, Ukraine). His research interests include radio measurement, development of devices for signal synthesis and Software Defined Radio.

ORCID ID: 0000-0002-4434-5794

Реалізація алгоритму пошуку кореляційного інтерферометричного пеленгатора засобами програмної платформи GNU радіо

Олексій Полікаровських^{1*}, Ігор Гула²

¹Кафедра технічної кібернетики й інформаційних технологій, Одеський національний морський університет, Одеса, Україна

² Кафедра фізики та електротехніки, Хмельницький національний університет, Хмельницький, Україна

*Автор-кореспондент (Електронна адреса: polalexey@gmail.com)

АНОТАЦІЯ У сфері розвитку сучасного радіообладнання широкого розповсюдження набула інтеграція програмно-визначених радіосистем (Software Defined Radio, SDR), що охоплюють як програмні, так і апаратні компоненти. SDR-системи, зокрема, знаходять застосування при створенні пеленгаторів джерел радіосигналів. Ефективність пеленгування та ідентифікації джерел радіовипромінювання значною мірою залежить від технічних характеристик обладнання. Для сучасних систем виявлення місцезнаходження джерел радіовипромінювання добре зарекомендували себе пеленгатори на основі кореляційного інтерферометра. Ці пеленгатори відмінно справляються з пеленгуванням широкого спектру радіосигналів, здатні розпізнавати ширококутові модульовані сигнали. Вони можуть одночасно обробляти та ідентифікувати кілька сигналів в межах одного частотного каналу, що походять як від одного джерела радіосигналів (когерентні), так і від декількох джерел (некогерентні). Технологія SDR дозволяє програмно змінювати конфігурацію радіоприймача за допомогою програмного забезпечення. Такі приймачі мають ширококутовий радіочастотний компонент зі значним динамічним діапазоном, високошвидкісний тракт аналого-цифрового перетворювача (АЦП), надійний сигнальний процесор і спеціалізований тракт цифрової фільтрації. SDR-приймачі адаптуються до сигналів різних стандартів і частот, залежно від конкретних завдань, що стоять перед ними. Програмна платформа GNU RADIO відома як найбільш гнучка програмна платформа з відкритим вихідним кодом для

систем SDR. Ця стаття присвячена використанню програмної платформи GNU RADIO для реалізації алгоритму пошуку для пеленгатора кореляційного інтерферометра. Для реалізації пеленгатора з використанням алгоритму кореляційного інтерферометра було обрано SDR-платформу Ettus USRP N210. В даній роботі представлено двоканальну програмно-керовану модель пеленгатора, що працює за алгоритмом кореляційного інтерферометра. Результати вимірювань кута розміщення джерел радіосигналу дали індивідуальну абсолютну похибку в діапазоні від 2 до 4 градусів, при середній абсолютній похибці близько 3 градусів. Ці результати є досить похвальними для таких мобільних двоканальних систем. Хоча системи з чотирма і більше каналами можуть похвалитися вищою точністю, вони, як правило, мають нижчу економічну доцільність.

КЛЮЧОВІ СЛОВА SDR, GNU RADIO, пеленгатор, алгоритм кореляційного інтерферометру .



This article is licensed under a Creative Commons Attribution 4.0 International License. To view a copy of this licence, visit <http://creativecommons.org/licenses/by/4.0/>.